

P143 Pressure Regulator

Second Stage

- Versatile
- Control Accuracy
- Compact Design
- Low Pressure Cut-Off Option

The Type P143 pressure regulator is ideal for natural gas, air, propane and general purpose gas pressure regulation. Uses include commercial, residential and light industrial for burners and unit heaters. The P143 has an internal relief device and is available in the low pressure cut off – LPCO – version.

Applications

Applicable to a wide range of gaseous fluids, including air, natural gas and propane. Can be used as a LP regulator.

Materials of Construction

	P143
Body, Bonnet	Iron, Aluminum
Diaphragm	Nitrile
Diaphragm Assembly	Zinc/Nitrile
Gaskets	Non-asbestos, CGR 2750
Pin	Stainless Steel
Vent Screen	Stainless Steel
Spring	Zinc-Plated Steel
Diaphragm Piston	Zinc-Plated Steel

Max Inlet Pressure

Orifice	Standard
1/8"	125
3/16"	125
1/4"	60
5/16"	40
3/8"	40
7/16"	-
1/2"	20
5/8"	10



- Valve Body Sizes: 3/4", 1", 1-1/4" NPT
- Vent Size: 1" NPT
- Temperature Range: -20°F to 150°F
- Approximate Weight: 6 lbs.

P143 Dimensions

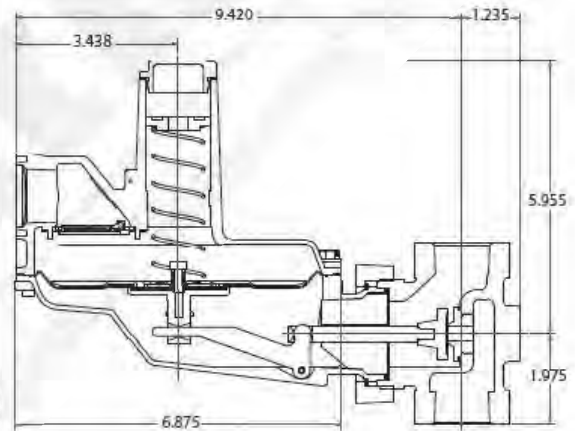

Spring Ranges

3.5" - 6.5" WC	Red
5" - 8.5" WC	Blue
6" - 14" WC	Green
12" - 33" WC	Orange
0.5 - 2.0 PSI	Purple
0.5 - 3.0 PSI	Yellow
2.0 - 6.0 PSI	Black

P143 Pressure Regulator

Propane Gas Capacities BTU/Hr (1.50 Specific Gravity)

Body Size 3/4" x 3/4"							
Inlet psig	Orifice						
	1/8"	3/16"	1/4"	5/16"	3/8"	1/2"	5/8"
1/2					535,500	708,750	803,250
1				756,000	787,500	803,250	834,750
2			834,750	882,000	897,750	913,500	945,000
3		661,500	945,000	882,000	992,250	1,023,750	1,055,250
5	393,750	882,000	1,102,500	1,134,000	1,149,750	1,212,750	1,244,250
8	488,250	1,102,500	1,323,000	1,354,500	1,386,000	1,417,500	1,417,500
10	582,750	1,307,250	1,496,250	1,527,750	1,575,000	1,606,500	1,606,500
20	834,750	1,890,000	1,921,500	1,953,000	1,968,750	2,000,250	
40	1,354,500	2,472,750	2,094,750	2,110,500	2,283,750		
60	1,890,000	2,614,500	2,394,000				

Body Size 3/4" x 1" • 1" X 1"							
Inlet psig	Orifice						
	1/8"	3/16"	1/4"	5/16"	3/8"	1/2"	5/8"
1/2					551,250	724,500	819,000
1				756,000	866,250	945,000	1,023,750
2			834,750	1,102,500	1,323,000	1,386,000	1,228,500
3		661,500	1,023,750	1,370,250	1,575,000	1,449,000	1,433,250
5	393,750	913,500	1,401,750	1,764,000	1,827,000	1,496,250	1,527,750
7.5	488,250	1,102,500	1,795,500	2,110,500	2,000,250	1,795,500	1,669,500
10	582,750	1,323,000	2,142,000	2,362,500	2,094,750	1,890,000	1,858,500
20	834,750	1,937,250	3,150,000	2,520,000	2,331,000	2,205,000	
40	1,354,500	2,677,500	3,150,000	2,583,000	2,992,500		
60	1,890,000	2,992,500	3,150,000				

Body Size 1" x 1-1/4" • 1-1/4" x 1-1/4"							
Inlet psig	Orifice						
	1/8"	3/16"	1/4"	5/16"	3/8"	1/2"	5/8"
1/2					551,250	724,500	819,000
1				756,000	866,250	1,071,000	1,197,000
2			834,750	1,102,500	1,323,000	1,606,500	1,622,250
3		661,500	1,023,750	1,370,250	1,622,250	1,890,000	1,653,750
5	393,750	913,500	1,401,750	1,858,500	2,126,250	2,346,750	1,669,500
7.5	488,250	1,102,500	1,795,500	2,362,500	2,535,750	2,488,500	1,669,500
10	582,750	1,323,000	2,142,000	2,677,500	2,693,250	2,835,000	1,858,500
20	992,250	1,937,250	2,520,000	2,835,000	2,992,500	2,992,500	
40	1,354,500	2,835,000	3,465,000	2,992,500	3,150,000		
60	1,890,000	3,307,500	3,780,000				